

Line	Units	Consumption	Load Factor	TLF	Peak Value	Peak Date	Peak Time
L1	kWh	4905265.00	65.93%	1.0000	18236.00	11-Sep-17	12:00
L2	kWh	8026749.00	61.13%	1.0000	18236.00	11-Sep-17	12:00
L3	kWh	8026685.41	61.14%	1.0000	18234.18	11-Sep-17	12:00
L4	kWh	7981569.09	61.08%	1.0000	18149.43	11-Sep-17	12:00



Revenue Metering

Background

Initial Conditions

Upgrades

Communications

Goals

Utility Environment

Thunder Bay Hydro Corporation



Thunder Bay Hydro Electricity Distribution Inc.

Thunder Bay Hydro Utility Services Inc.(MSP)

Thunder Bay Hydro Renewable Power Inc.



Market Open

Electro-Mechanical
Meters, Recorders and
phase shifting
transformers



Pulse Relays

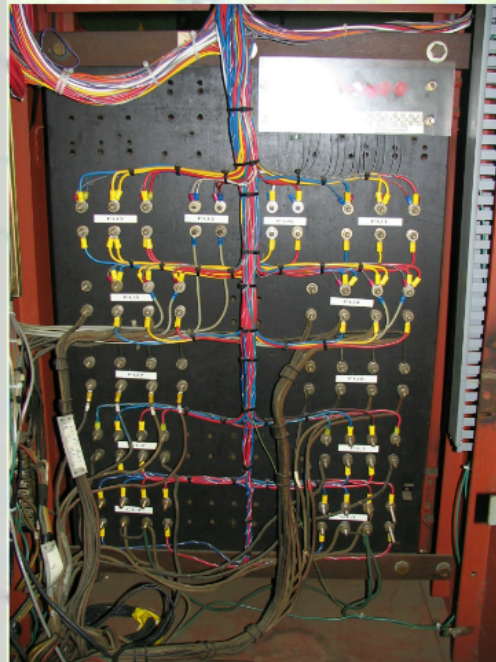

Panels within P&C LineUp

Shared ITs

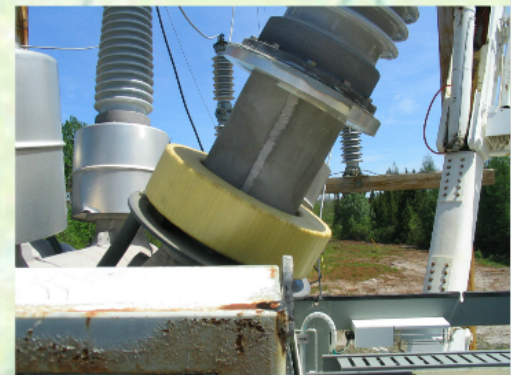



Legacy Challenges

CT summing, TX Bank

69V secondaries

Panels

3L-N vs 2L-L VTs

2 ELEMENT METERING USING 3 VTS

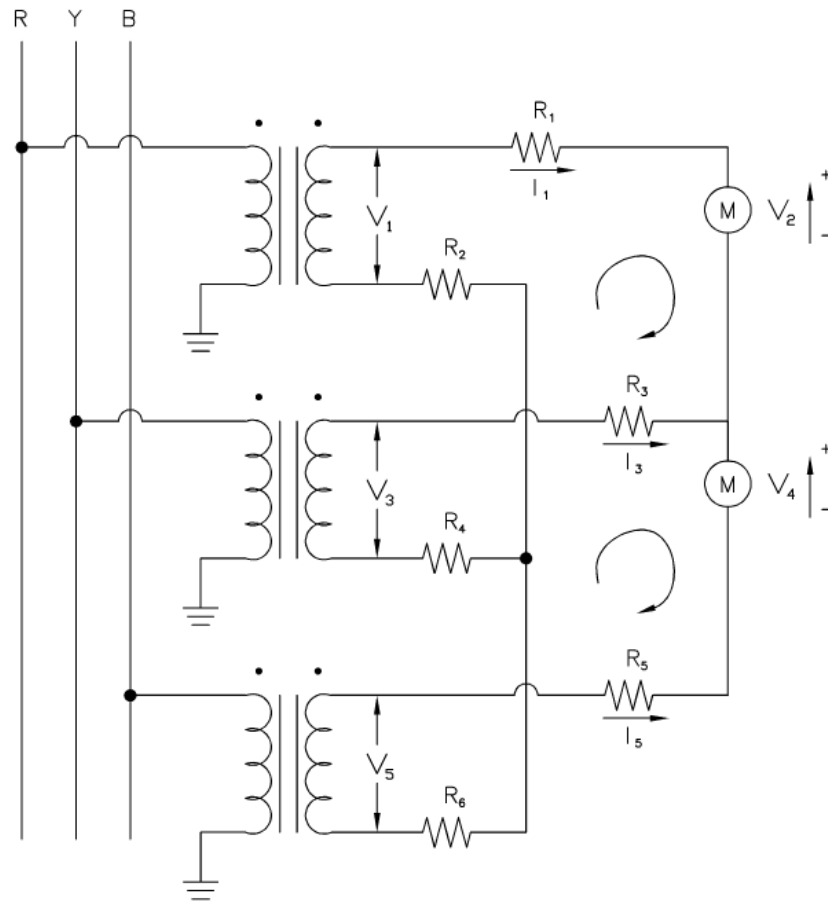



Stepping Into Compliance

Conforming Meters

Dryden

Panels into Cabinets

New ITs

-

Panel Construction

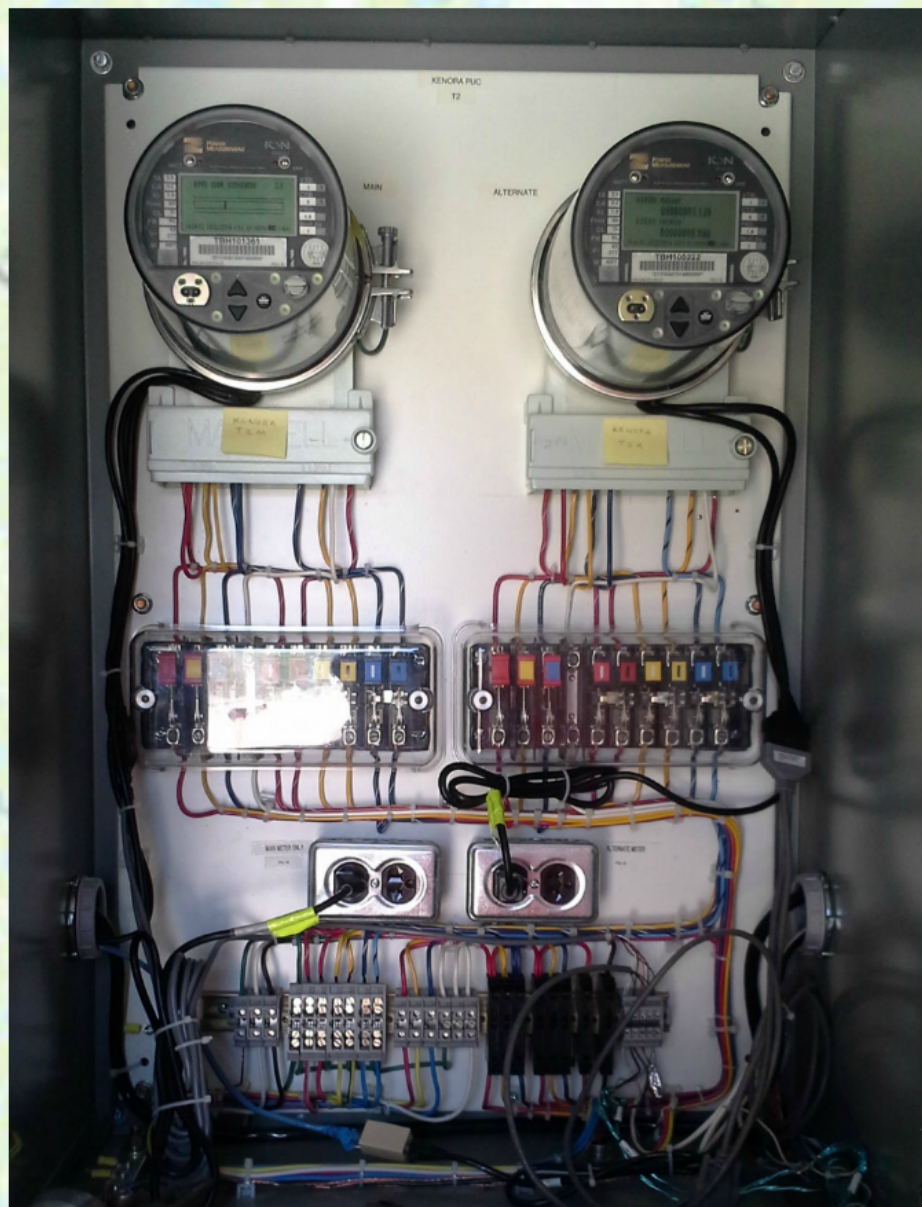

Relocating Metering Components

Outside Building



Dryden

Eagle L Beyond Station





More Photos



the Woods

Communication Configurations

Typical



• 485m

Advanced

Dryden



Eagle Lake

Problematic



Typical

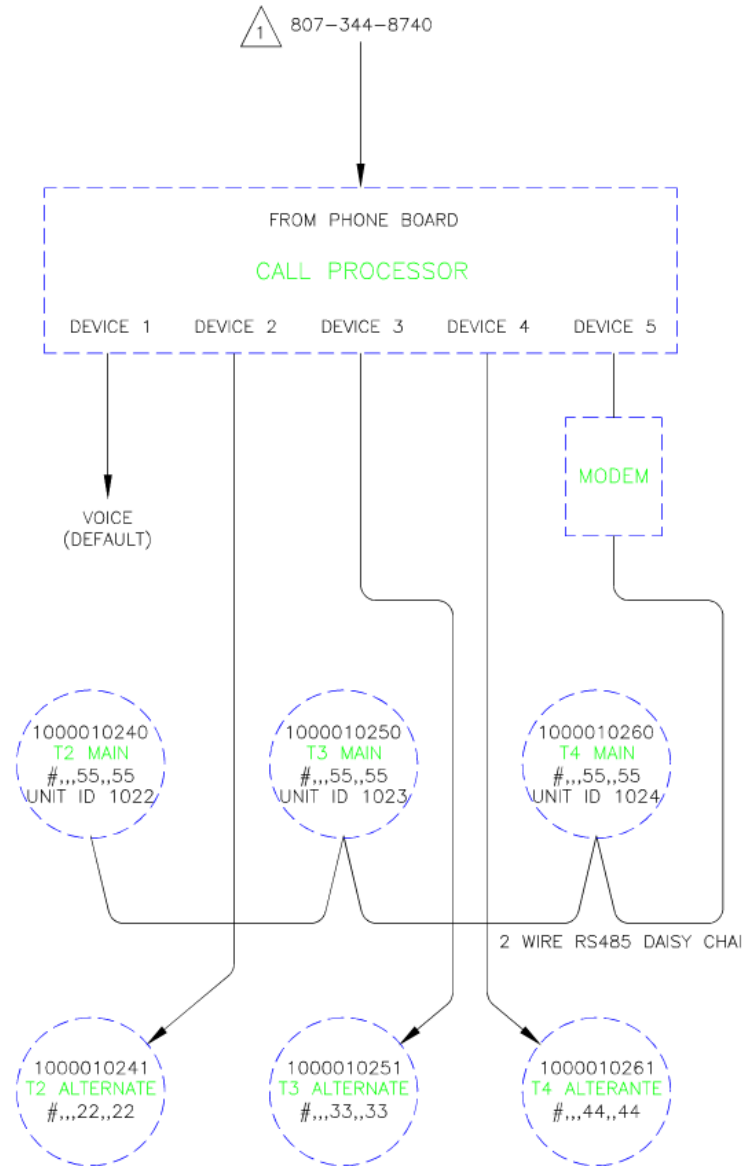

Advanced

IESO METERING CABINETS

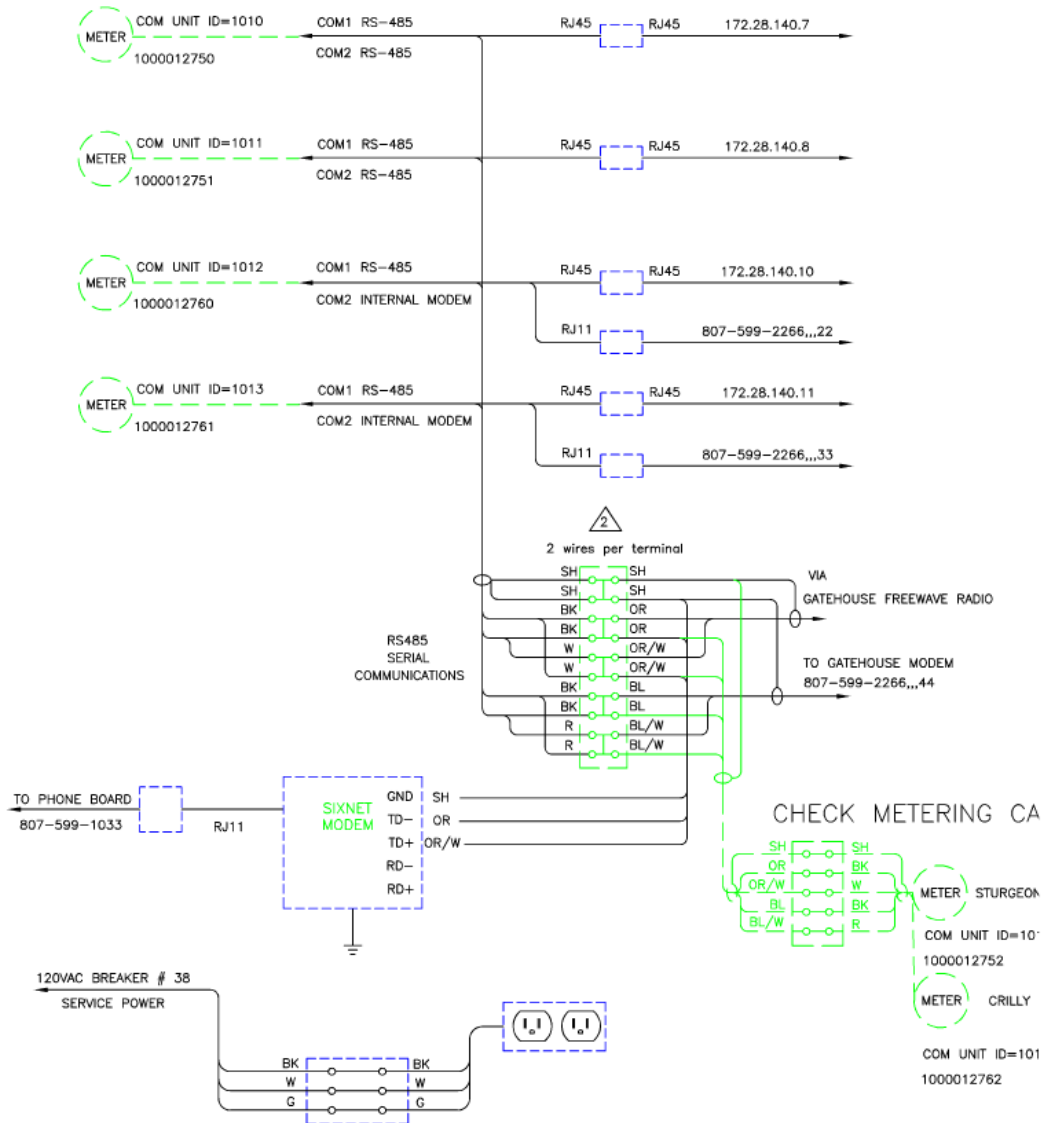

CABINET WIRING



Advanced

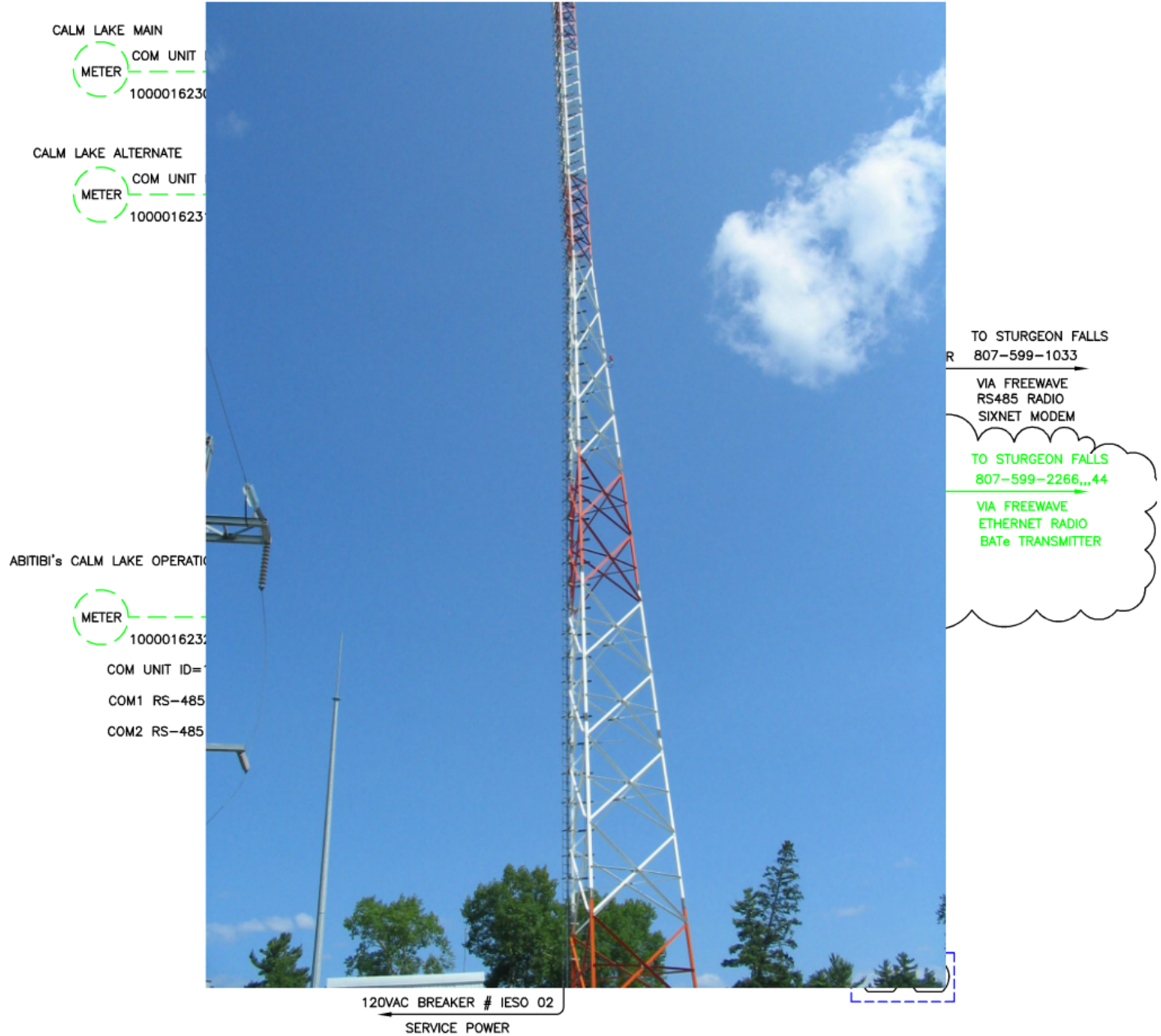

DIAL UP 4 METERS 2 PHONE LINES

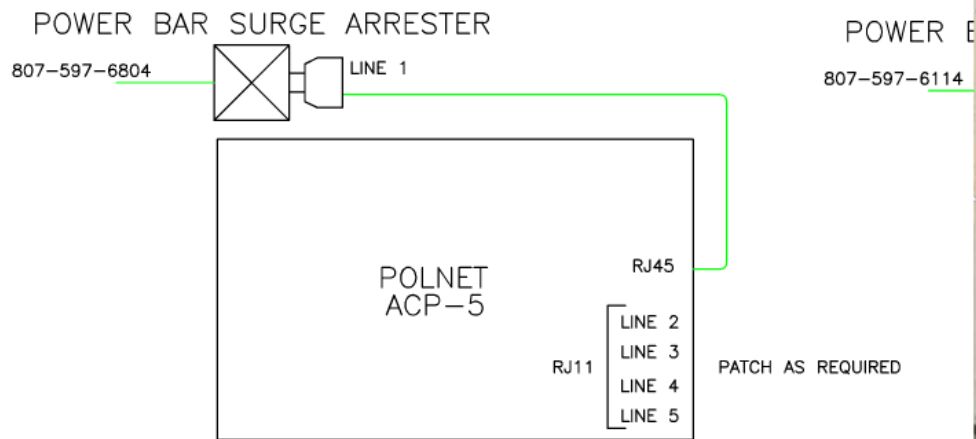

COM CABINET WIRING



TCP-IP with 2 Cell Modems

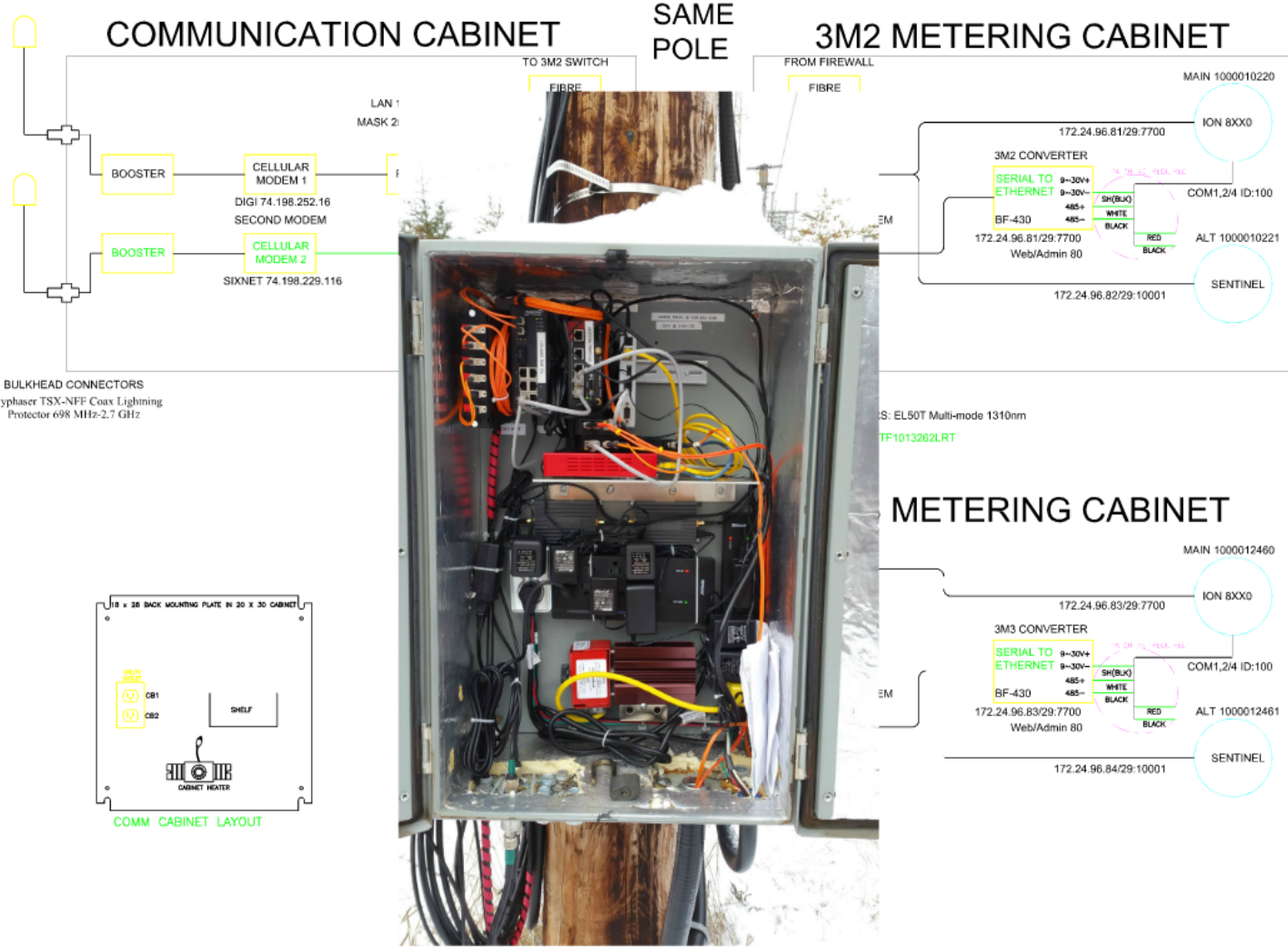

TCP-IP vs Dial Up Demo

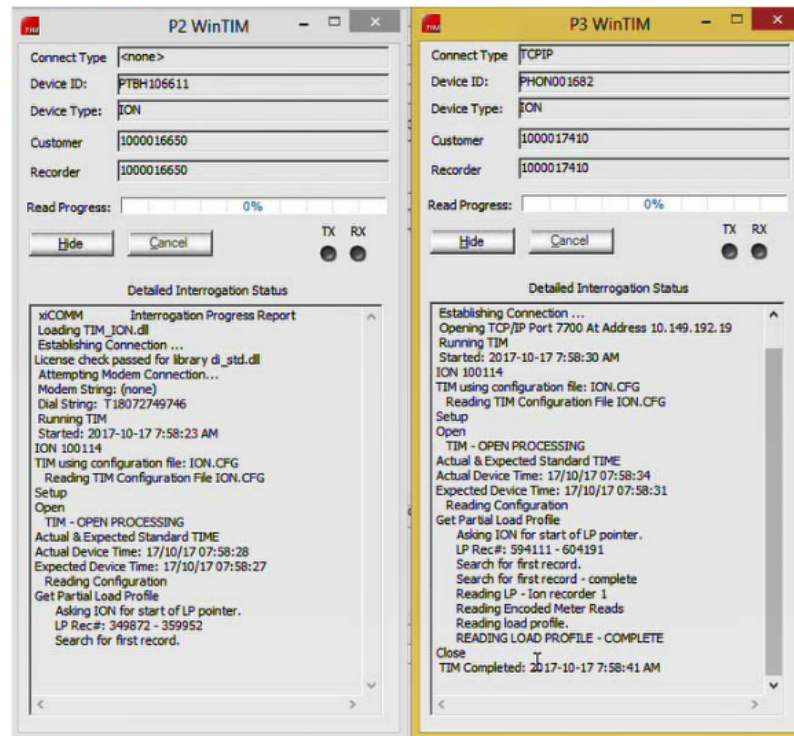

Dial-Up (Left) VS TCP-IP (Right)

1 to 3+

Interval Metered Facilities

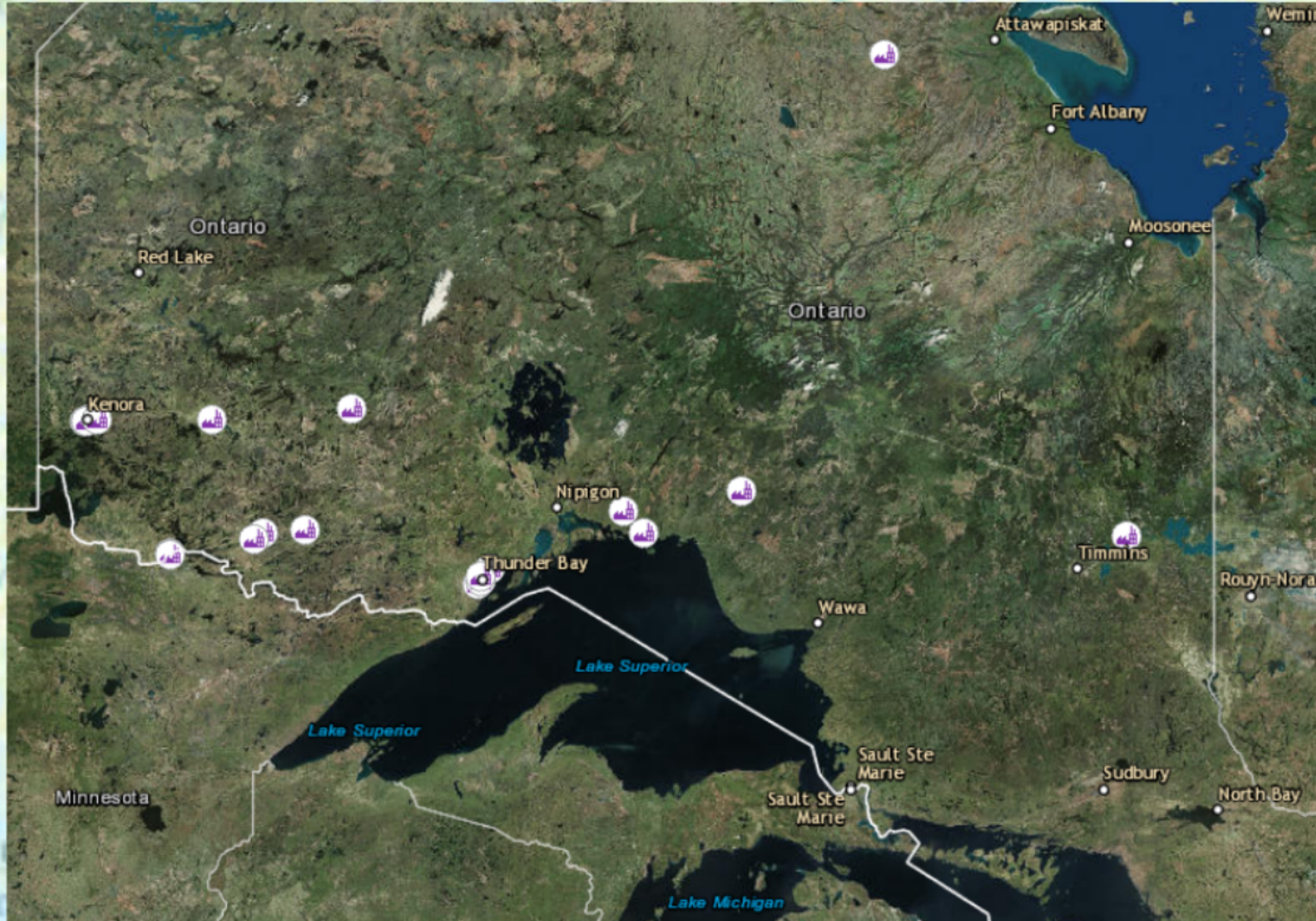

200 nightly reads

100 ION 7xxx & 8xx0 meters

ION Meter Distribution

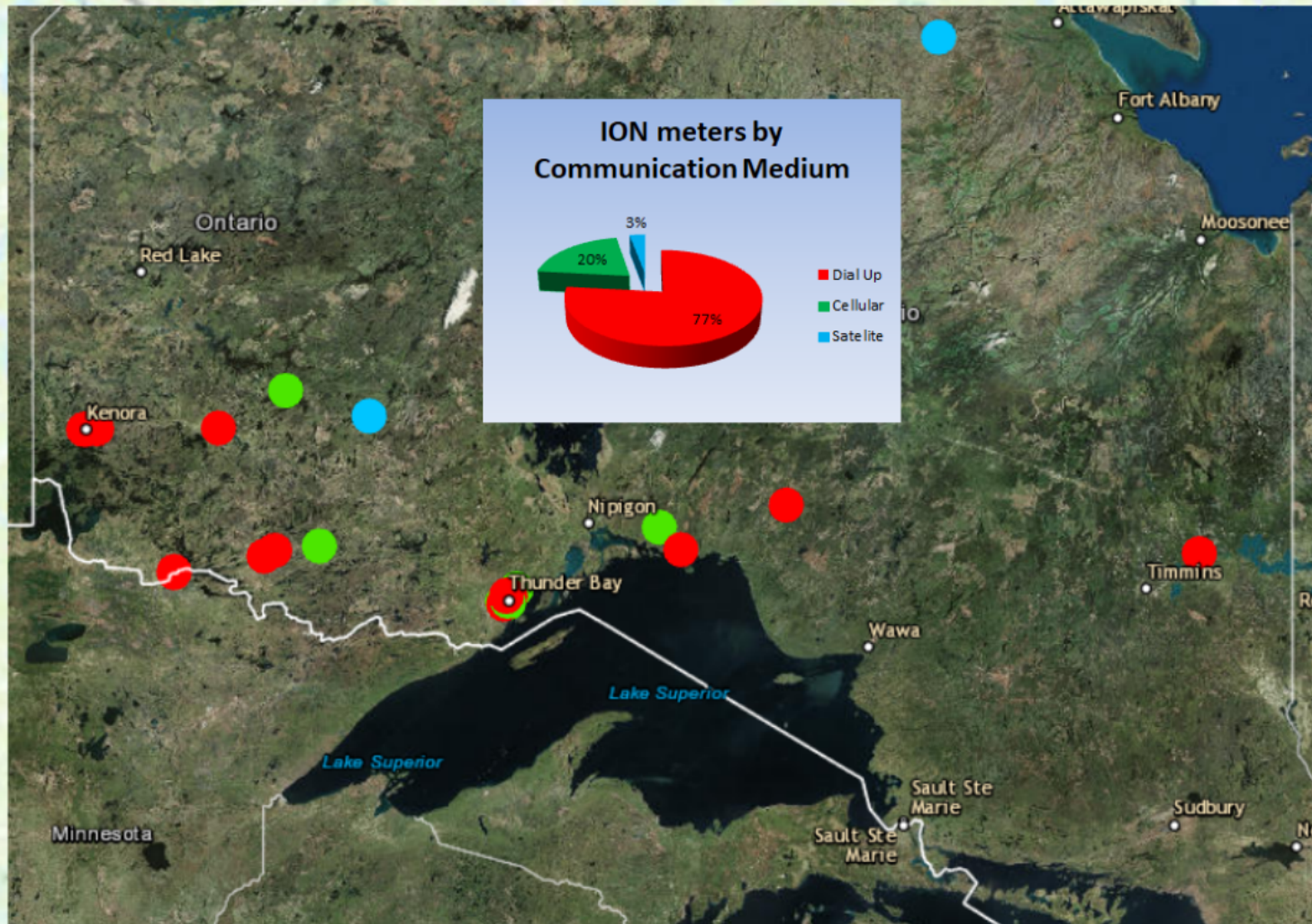

20 TCP-IP, Target 50

3 Satellite, 2 Corp VPN

Cell 3G/4G Yagi/Booster

A topographic map of a region, likely in the Andes, showing terrain contours, rivers, and a road network. A grey frame is overlaid on the map. A scale bar in the bottom right corner indicates a distance of 691 meters. The text 'Quetico Provincial Park' is visible at the bottom of the map.

Goals

Convert to TCP-IP

Upcoming Seal Expiries

Improve Communications

Reduce MTRs

Quetico
Provincial Park

691 m



Questions